

# Die Button Table Headless Type (PDB)

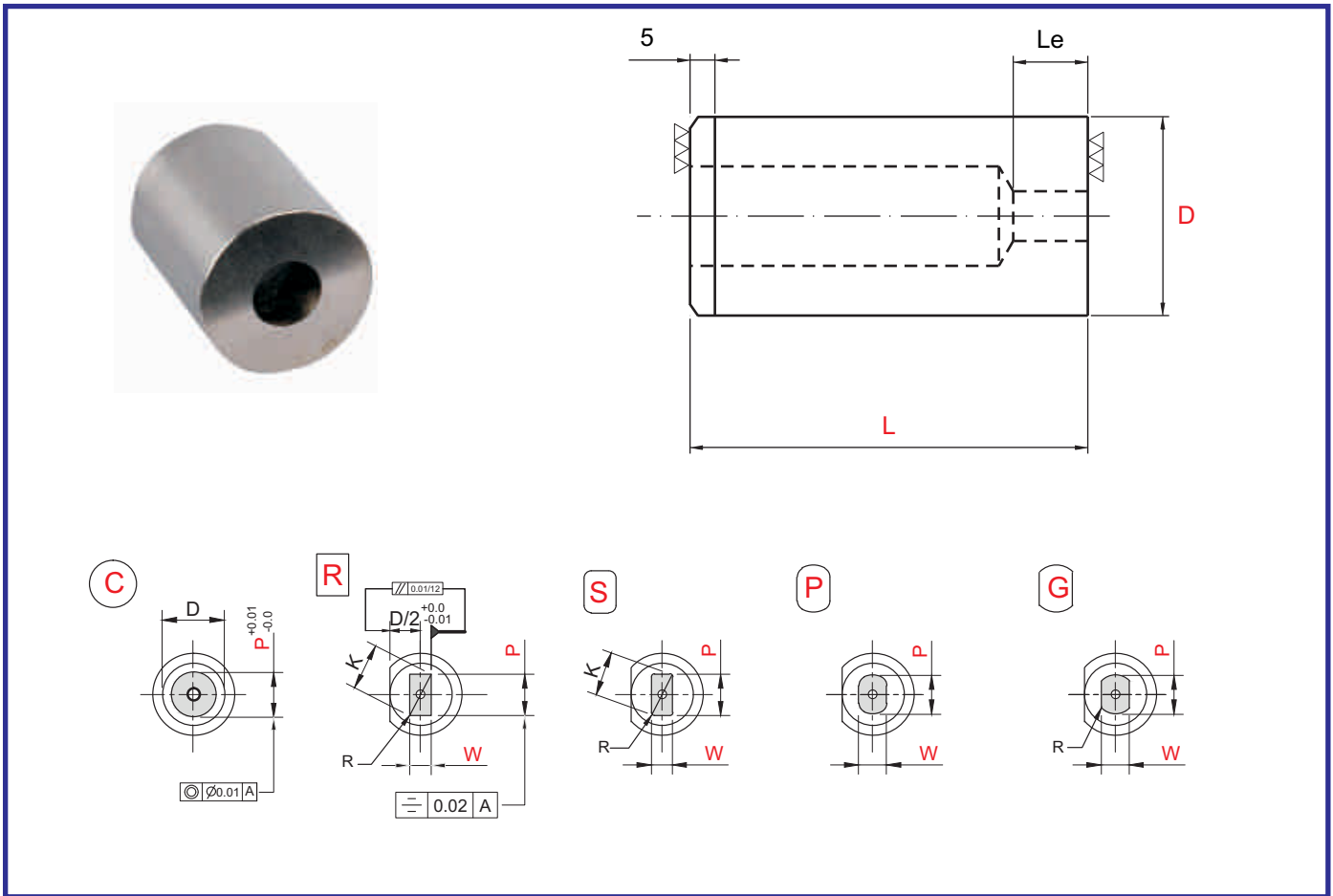

**Material :-** High Speed Steel (Grade M2)/ HcHcr (Grade D2)  
**Hardness :-** 60-62 Hrc

Size	Code	Type	D	d	d - K	d - b	L					Le	
Tolerance			m5	+ 0.02(max)	max	min	+0.5(max)						
	PDB	C,R,P,S,G	6	1.50 - 3.00	3.00	2.00	16	20	25	30	35		3
			8	1.50 - 4.00	4.00	2.00	16	20	25	30	35	40	4
			10	2.00 - 6.00	6.00	2.00	16	20	25	30	35	40	6
			13	3.00 - 8.00	8.00	2.00	16	20	25	30	35	40	8
			16	5.00 - 10.00	10.00	3.00	16	20	25	30	35	40	8
			20	7.00 - 12.00	12.00	3.00	16	20	25	30	35	40	8
			22	8.00 - 14.00	14.00	3.00	16	20	25	30	35	40	8
			25	10.00 - 16.00	16.00	3.00	16	20	25	30	35	40	8
			32	15.00 - 20.00	20.00	4.00	16	20	25	30	35	40	8
			38	19.00 - 26.00	26.00	5.00	16	20	25	30	35	40	8
			45	25.00 - 35.00	35.00	6.00		20	25	30	35	40	8
			50	33.00 - 40.00	40.00	7.00		20	25	30	35	40	8
	56	38.00 - 45.00	45.00	8.00		20	25	30	35	40	8		

**Order Type :-** Code X Type X Dia D - d - (K/b) X Length L  
**Example :-** PDB X R X 16 - 8 - (8.94) X 35